ONE PART PLACED BETWEEN STIFFENERS

1.0 SCOPE

This standard provides a method for the packaging of large seals, gaskets, rings, etc., providing protection from distortion, creasing, kinking, etc.

2.0 REFERENCES

2.1 Lockheed Packaging Standard LPS 40-001

2.2 NAS Standard 3415

3.0 REQUIREMENTS

3.1 GENERAL

3.1.1 Unless otherwise specified, the quantity per unit package shall be one (1) each.

3.1.2 Items shall be thoroughly clean before packaging.

3.1.3 Unless otherwise specified, the item(s) shall not be coiled or otherwise distorted from its original shape.

3.1.4 Package size shall be commensurate with the size of the item.

3.1.5 Items shall be supported with a stiffener material of sufficient rigidity to prevent distortion during handling/shipping. Stiffeners shall extend beyond the item on all sides. (See Figure 1.)

3.1.6 Items subject to distortion from compression forces shall be protected with a stiffener and bonded spacer, designed to prevent stiffener sections from bearing directly on the item. (See Figure 2.)

3.2 UNIT PACKAGING

3.2.1 Place item in a clear plastic bag. Close bag by heat sealing. Allow sufficient plastic material to permit at least one additional reseal.

NOTE: Exclude plastic bag when Figure 2 package is used.

3.2.2 Seal sandwich sections with tape.

CAUTION: AVOID KINKING OR CREASING THE ITEM(S).

3.3 INTERMEDIATE PACKAGING (Consolidation of Unit Packages)

3.3.1 Pack unit packages containing identical items uniformly into fiberboard containers. Only those items having the same part number and cure date may be placed within an intermediate container. Gross weight/dimensions of each container shall not exceed its design specifications.

3.3.2 Fill all voids with suitable dunnage, blocking or bracing as required.

3.4 PACKING

3.4.1 Pack any number of intermediate containers uniformly into each shipping container.

3.4.2 Shipping containers as packed, shall protect each item and package during ordinary handling and shipping and shall meet the requirements of the common carriers for acceptance for safe transportation at the lowest rate to the point of delivery.

3.4.3 Intermediate containers which meet the requirements of Paragraph 3.4.2 may be used as shipping containers.

3.4.4 Enclose or attach a copy of packing slip to the shipping container.

3.5 MARKING

3.5.1 Unit Packaging Marking – Label or mark each package to show at least the part number per contracting document, nomenclature, and supplier identity. Additional markings may be specified in the item detail specification or drawing.

3.5.2 Intermediate Packaging Marking – Label or mark each container to show, at least, part number per contracting document, supplier and quantity of parts.

3.5.3 Shipping Container Marking – Label or mark each container to show part number per contracting document, the LMSC contracting document number, supplier, destination and quantity of parts.

3.5.4 Special, precautionary and handling markings shall be applied as required.

4.0 QUALITY ASSURANCE

4.1 Packaging shall be accomplished in such a manner as to prevent physical damage to, or degradation of, the packaged items during delivery to the using activity. It shall be the prerogative of LMSC to return damaged items, at supplier's expense, when such damage is attributable to improper or inadequate protections.

5.0 NOTES

5.1 The following information is intended as a guide or aid to suppliers in meeting the requirements of this specification.

5.1.1 REFERENCES

<u>Commodity</u>	<u>Military Specifications</u>
Box, Fiberboard	PPP-B-636
Cushioning, Free Flow	MIL-C-23734
Fiberboard, Corrugated	PPP-F-320
Sheet, Plastic	L-P-378

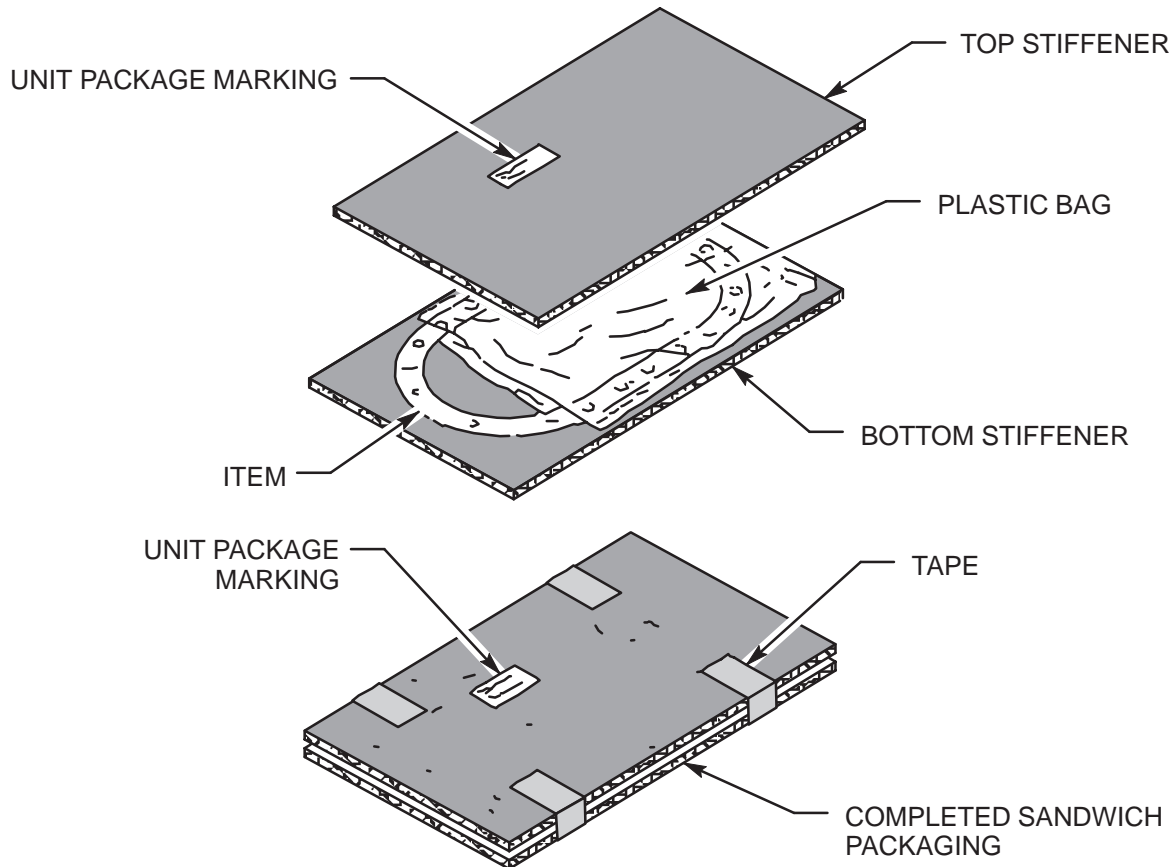

Figure 1. Unit Package (without Spacer)

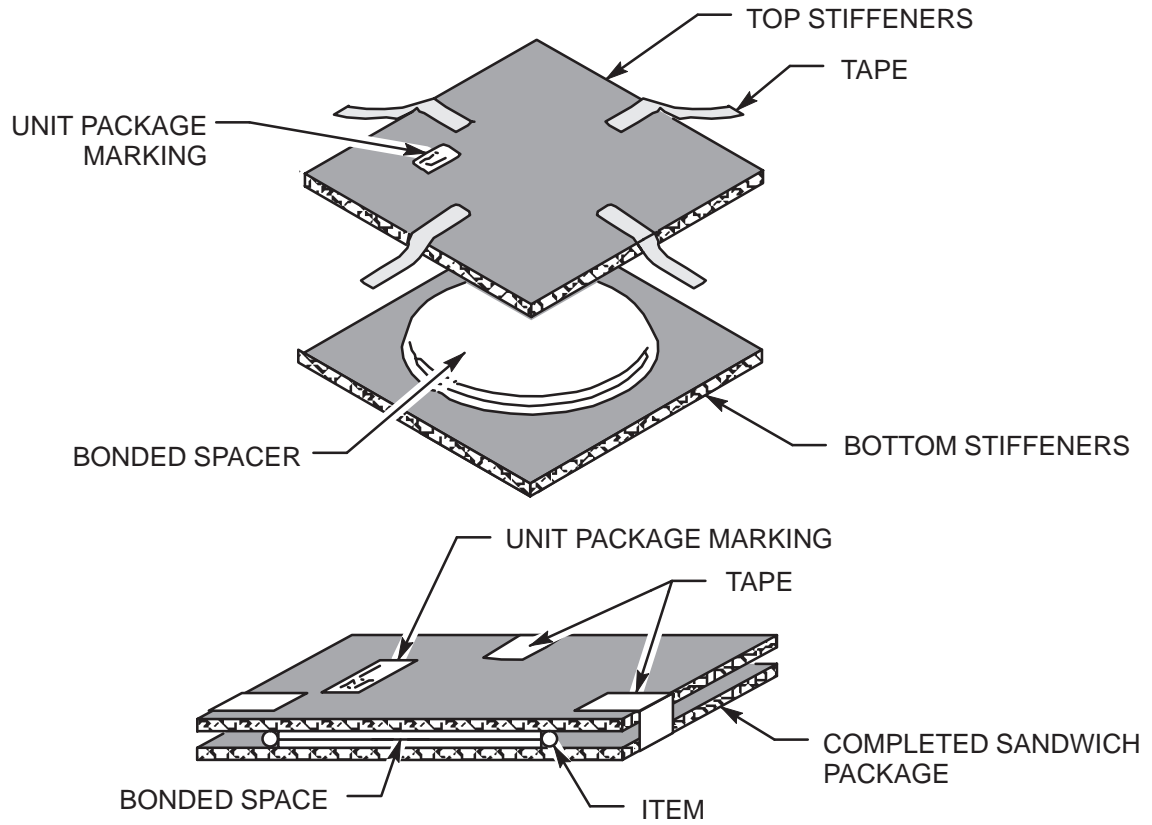

Figure 2. Unit Package (with Spacer)